

Wipers

K

(Inch Size)

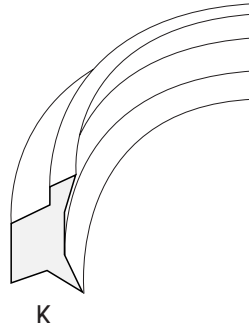

Material	Temp. (°c)	Speed (m/s)
PU	-35 +95	0.5

- One piece snap in type.
- Good scraping effect.
- High wear resistance.
- Long service life.

Installation Recommendation

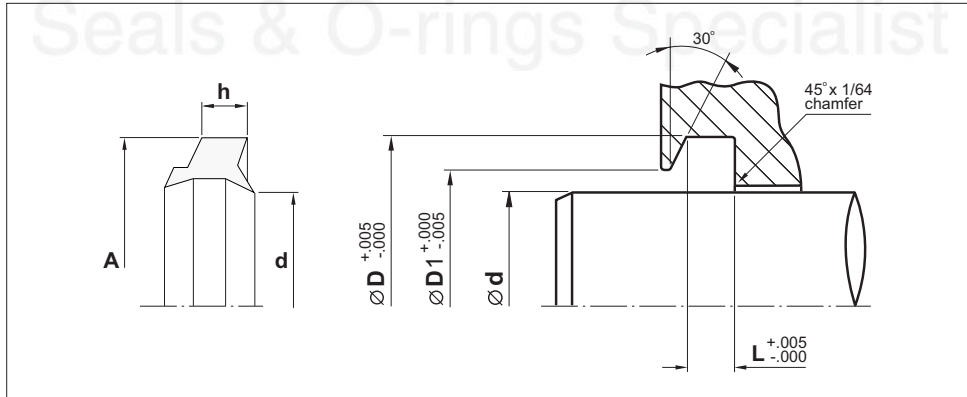

Surface roughness

µin CLA

Sliding surface	4 to 16
Surface of housing	63 max
Sides of housing	125 max

Wiper - K

(Inch Size)

Rod Dia.	Wiper Dimensions		Groove Dimensions			Reference (For order processing)
	Outer Dia.	Seal Step Height	Groove Dia.	Groove Width	Bore Dia.	
d	A	h	D	L	D1	
1/2	3/4	.150	.760	.155	.625	K-00500
9/16	13/16	.150	.822	.155	.687	K-00562
5/8	7/8	.150	.885	.155	.750	K-00625
11/16	15/16	.150	.947	.155	.812	K-00687
3/4	1-1/8	.190	1.135	.195	.832	K-00750
13/16	1-13/16	.190	1.197	.195	.894	K-00812
7/8	1-1/4	.190	1.260	.195	.957	K-00875
15/16	1-5/16	.190	1.322	.195	1.019	K-00937
1	1-3/8	.190	1.385	.195	1.082	K-01000
1-1/16	1-7/16	.190	1.447	.195	1.144	K-01062
1-1/8	1-1/2	.190	1.510	.195	1.207	K-01125
1-3/16	1-9/16	.190	1.572	.195	1.269	K-01187
1-1/4	1-5/8	.190	1.635	.195	1.332	K-01250
1-5/16	1-11/16	.190	1.697	.195	1.394	K-01312
1-3/8	1-3/4	.190	1.760	.195	1.457	K-01375
1-7/16	1-13/16	.190	1.822	.195	1.519	K-01437
1-1/2	1-7/8	.190	1.885	.195	1.582	K-01500
1-9/16	1-15/16	.190	1.947	.195	1.644	K-01562
1-5/8	2	.190	2.010	.195	1.707	K-01625
1-11/16	2-1/16	.190	2.072	.195	1.769	K-01687
1-3/4	2-1/8	.190	2.135	.195	1.832	K-01750
1-13/16	2-3/16	.190	2.197	.195	1.894	K-01812
1-7/8	2-1/4	.190	2.260	.195	1.957	K-01875
1-15/16	2-5/16	.190	2.322	.195	2.019	K-01937
2	2-3/8	.190	2.385	.195	2.082	K-02000
2-1/8	2-1/2	.190	2.510	.195	2.207	K-02125
2-1/4	2-3/4	.250	2.760	.255	2.407	K-02250
2-3/8	2-7/8	.250	2.885	.255	2.532	K-02375
2-1/2	3	.250	3.010	.255	2.657	K-02500
2-5/8	3-1/8	.250	3.135	.255	2.782	K-02625
2-3/4	3-1/4	.250	3.260	.255	2.907	K-02750
2-7/8	3-3/8	.250	3.385	.255	3.032	K-02875
3	3-1/2	.250	3.510	.255	3.157	K-03000
3-1/8	3-5/8	.250	3.635	.255	3.282	K-03125
3-1/4	3-3/4	.250	3.760	.255	3.407	K-03250
3-3/8	3-7/8	.250	3.885	.255	3.532	K-03375
3-1/2	4	.250	4.010	.255	3.657	K-03500
3-5/8	4-1/8	.250	4.135	.255	3.782	K-03625
3-3/4	4-1/4	.250	4.260	.255	3.907	K-03750
3-7/8	4-3/8	.250	4.385	.255	4.032	K-03875

Wiper - K

(Inch Size)

Rod Dia.	Wiper Dimensions		Groove Dimensions			Reference (For order processing)
	Outer Dia.	Seal Step Height	Groove Dia.	Groove Width	Bore Dia.	
d	A	h	D	L	D1	
4	4-1/2	.250	4.510	.255	4.157	K-04000
4-1/8	4-5/8	.250	4.635	.255	4.282	K-04125
4-1/4	4-3/4	.250	4.760	.255	4.407	K-04250
4-3/8	4-7/8	.250	4.885	.255	4.532	K-04375
4-1/2	5	.250	5.010	.255	4.657	K-04500
4-5/8	5-1/8	.250	5.135	.255	4.782	K-04625
4-3/4	5-1/4	.250	5.260	.255	4.907	K-04750
4-7/8	5-3/8	.250	5.385	.255	5.032	K-04875
5	5-1/2	.250	5.510	.255	5.157	K-05000
5-1/4	5-3/4	.250	5.760	.255	5.407	K-05250
5-1/2	6	.250	6.010	.255	5.657	K-05500
5-3/4	6-1/4	.250	6.260	.255	5.907	K-05750
6	6-1/2	.250	6.510	.255	6.157	K-06000
6-1/4	6-3/4	.250	6.760	.255	6.407	K-06250
6-1/2	7	.250	7.010	.255	6.657	K-06500
6-3/4	7-1/4	.250	7.260	.255	6.907	K-06750
7	7-1/2	.250	7.510	.255	7.157	K-07000
7-1/2	8	.250	8.010	.255	7.657	K-07500
8	8-1/2	.250	8.510	.255	8.157	K-08000
8-1/2	9	.250	9.010	.255	8.657	K-08500
9	9-1/2	.250	9.510	.255	9.157	K-09000
9-1/2	10	.250	10.010	.255	9.657	K-09500
10	10-1/2	.250	10.510	.255	10.157	K-10000