

Piston Seals

PKK

(Metric Size)

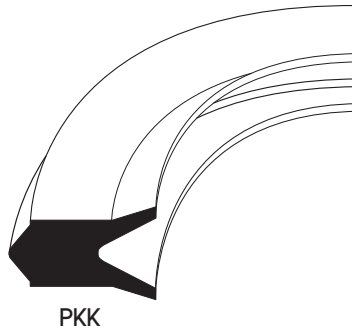

Material	Pressure (Bar)	Temp. (°C)	Speed (m/s)
NBR	16	-40 +80	1

- Piston seal for pneumatic systems
- Pressure admission on one side or both sides.
- Low friction.
- Long service life.

Installation Recommendation

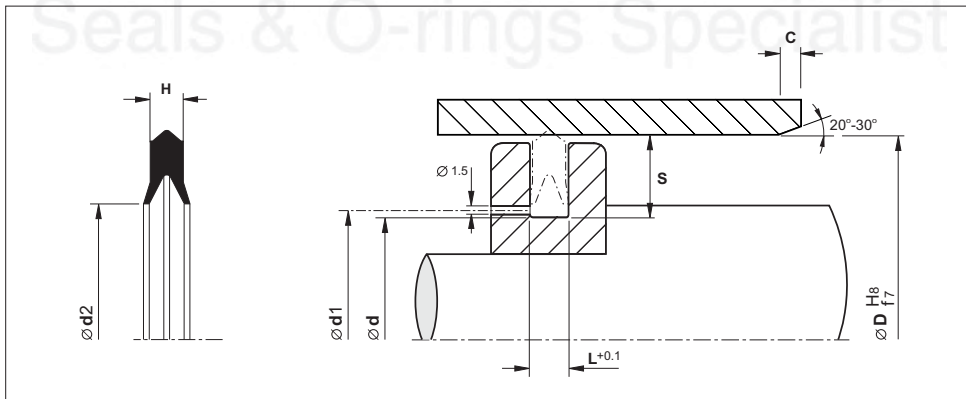

Surface roughness	Ra		Rmax		Chamfers	
	S	C	S	C	S	C
Sliding surface	≤ 0.3 μm	≤ 2.5 μm	≤ 2.5 μm	≤ 2.5 μm	4.0	2.0
Surface of housing	≤ 1.6 μm	≤ 6.3 μm	≤ 6.3 μm	≤ 6.3 μm	5.0	2.5
Sides of housing	≤ 3.0 μm	≤ 15 μm	≤ 15 μm	≤ 15 μm	7.5	4.0
					10.0	5.0
					12.5	6.5
					15.0	7.5
					20.0	10.0

# Piston - PKK



(Metric Size)

Bore Dia.	Dimensions		Groove Width	Seal Height	Seal Dia.	Reference	Reference (For order processing)
	D	d					
12	5.2	6.8	1.7	1.5	7.2	2-9826	PKK-012
15	5.2	6.8	2.3	2.0	7.4	2-9963	PKK-015
18	7.5	9.2	2.3	2.0	10.4	2-11072	PKK-018
20	9.5	11.2	2.3	2.0	12.4	2-11871	PKK-020
30	19.5	21.2	2.3	2.0	22.4	2-9571	PKK-030
30	21.0	22.7	1.7	1.5	24.2	2-9573	PKK-030A
32	21.5	23.2	2.3	2.0	24.4	2-11518	PKK-032
35	21.5	23.2	3.0	2.5	25.0	2-11718	PKK-035
40	26.5	28.2	3.0	2.5	30.0	2-9475	PKK-040
45	31.5	33.2	3.0	2.5	35.0	2-9466	PKK-045
50	36.5	38.2	3.0	2.5	39.0	2-11184	PKK-050
60	42.5	44.2	3.5	3.0	46.0	2-9572	PKK-060
63	45.5	47.5	3.5	3.0	49.0	2-11235	PKK-063
70	54.5	56.2	3.5	3.0	58.0	2-9701	PKK-070
80	60.0	61.7	4.1	3.5	63.4	2-11313	PKK-080
82	62.0	63.7	4.1	3.5	65.4	2-9846	PKK-082
100	80.0	81.7	4.6	4.0	83.4	2-11519	PKK-100
102	82.0	83.7	4.6	4.0	85.4	2-9931	PKK-102
118	95.0	96.7	5.1	4.5	99.0	2-11010	PKK-118
125	100.0	101.7	5.1	4.5	104.4	2-9476	PKK-125
127	102.0	103.7	5.1	4.5	106.4	2-9806	PKK-127
150	122.5	124.0	6.2	5.5	126.4	2-9932	PKK-150
160	132.0	134.0	6.2	5.5	135.6	2-9995	PKK-160
175	148.0	150.0	6.7	6.0	151.0	2-11335	PKK-175
180	152.0	154.0	6.7	6.0	156.0	2-9799	PKK-180
222	186.0	188.0	8.8	8.0	190.0	2-11044	PKK-222
255	219.0	221.0	8.8	8.0	223.0	2-11045	PKK-255