

Piston Seals

PSD

(Metric Size)

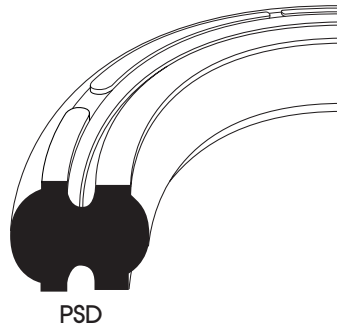

Material	Pressure (Bar)	Temp. (°C)	Speed (m/s)
NBR	10	-20 +80	1

- Compact packings used exclusively of double acting piston.
- Excellent frictional resistance.
- Anti-twisting and distortion.
- Long service life.

Installation Recommendation

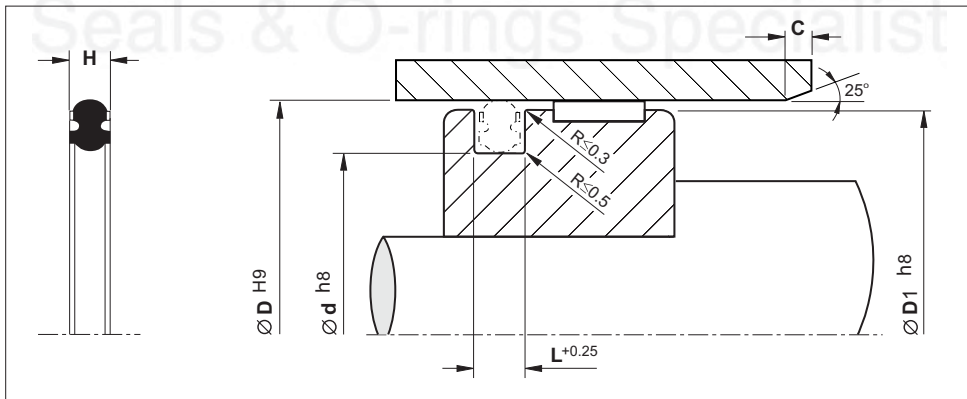

Surface roughness	Ra	Rmax
-------------------	----	------

Sliding surface	≤ 0.3 μm	≤ 2.5 μm
Surface of housing	≤ 1.6 μm	≤ 6.3 μm
Sides of housing	≤ 3.0 μm	≤ 15 μm

Piston - PSD

(Metric Size)

Bore Dia.	Groove Dia.	Groove Width	Seal Height	Piston Dia.	Chamfer Length	Reference (For order processing)
D	d	L	H	D1	C	
10.0	5.4	1.8	1.6	9.7	1.0	PSD-010
12.0	7.4	1.8	1.6	11.7	1.0	PSD-012
15.0	10.4	1.8	1.6	14.7	1.0	PSD-015
16.0	11.4	1.8	1.6	15.7	1.0	PSD-016
20.0	14.0	2.4	2.24	19.5	1.5	PSD-020
25.0	17.0	3.2	3.0	24.5	2.0	PSD-025
30.0	22.0	3.2	3.0	29.5	2.0	PSD-030
32.0	24.0	3.2	3.0	31.5	2.0	PSD-032
38.0	30.0	3.2	3.0	37.5	2.0	PSD-038
40.0	32.0	3.2	3.0	39.5	2.0	PSD-040
44.0	36.0	3.2	3.0	43.5	2.0	PSD-044
50.0	40.0	4.0	3.8	49.5	2.5	PSD-050
56.0	46.0	4.0	3.8	55.5	2.5	PSD-056
60.0	50.0	4.0	3.8	59.5	2.5	PSD-060
63.0	53.0	4.0	3.8	62.4	2.5	PSD-063
70.0	55.0	6.0	5.6	69.4	3.0	PSD-070
75.0	60.0	6.0	5.6	74.4	3.0	PSD-075
80.0	65.0	6.0	5.6	79.4	3.0	PSD-080
85.0	70.0	6.0	5.6	84.4	3.0	PSD-085
90.0	75.0	6.0	5.6	89.4	3.0	PSD-090
95.0	80.0	6.0	5.6	94.4	3.0	PSD-095
100.0	85.0	6.0	5.6	99.4	3.0	PSD-100
110.0	95.0	6.0	5.6	109.3	3.0	PSD-110
120.0	105.0	6.0	5.6	119.3	3.5	PSD-120
125.0	110.0	6.0	5.6	124.3	3.5	PSD-125
140.0	125.0	6.0	5.6	139.3	3.5	PSD-140
150.0	135.0	6.0	5.6	149.3	3.5	PSD-150
160.0	140.0	8.0	7.6	159.3	5.0	PSD-160
175.0	155.0	8.0	7.6	174.3	5.0	PSD-175
180.0	160.0	8.0	7.6	179.3	5.0	PSD-180
200.0	180.0	8.0	7.6	199.0	5.0	PSD-200
250.0	230.0	8.0	7.6	249.0	5.0	PSD-250
300.0	280.0	8.0	7.6	299.0	5.0	PSD-300