

## Wipers

PW/HH

(Metric Size)

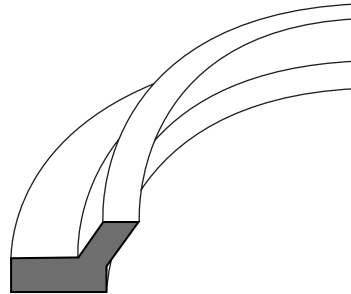

PW/HH (PU)

Material	Temp. (°c)	Speed (m/s)
PU	-40 +95	1

- High wear resistance.
- Good prevention against external fluid intrusion.
- Easy installation.
- Space-saving construction.

### Installation Recommendation

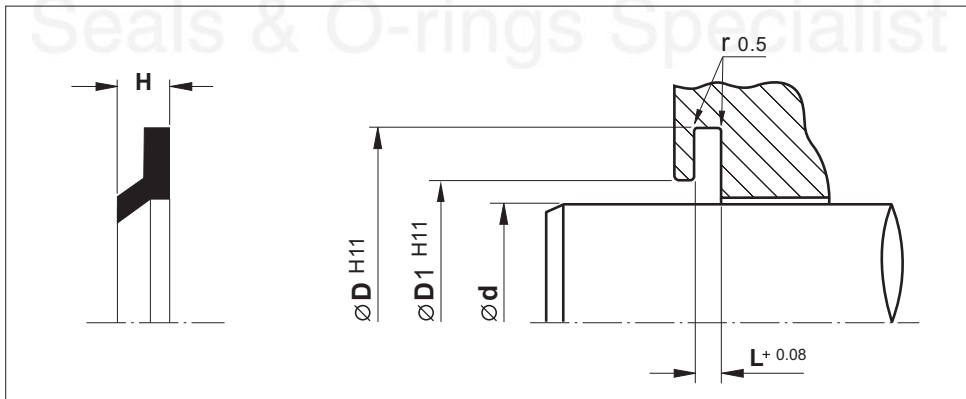

Surface roughness	Ra	Rt
Sliding surface	≤ 0.3 µm	≤ 4 µm
Surface of housing	≤ 1.8 µm	≤ 10 µm
Sides of housing	≤ 3.0 µm	≤ 16 µm

# Wiper - PW/HH

(Metric Size)

Rod Dia.	Groove Dia.	Groove Width.	Seal Height	Bore Dia.	Reference (For order processing)	Reference (For order processing)
d	D	L	H	D1		
18.0	24.0	1.30	2.5	20.1		EDK 18
25.0	32.5	1.60	3.0	27.9	PW/HH 25-32.5-1.6/27.9	EDK 25
30.0	37.5	1.60	3.0	32.9		EDK 30
32.0	39.5	1.60	3.0	34.9	PW/HH 32-39.5-1.6/34.9	EDK 32
33.0	40.5	1.60	3.0	35.9	PW/HH 33-40.5-1.6/35.9	
35.0	42.5	1.60	3.0	37.9		EDK 35
40.0	47.5	1.60	3.0	42.9	PW/HH 40-47.5-1.6/42.9	EDK 40
43.0	50.5	1.60	3.0	45.9		EDK 43
45.0	52.5	1.60	3.0	47.9	PW/HH 45-52.5-1.6/47.9	EDK 45
50.0	60.0	2.15	4.0	54.6	PW/HH 50-60-2.15/54.6	EDK 50
55.0	65.0	2.15	4.0	59.6	PW/HH 55-65-2.15/59.6	EDK 55
60.0	70.0	2.15	4.0	64.6		EDK 60
63.0	73.0	2.15	4.0	67.6	PW/HH 63-73-2.15/67.6	EDK 63
65.0	75.0	2.15	4.0	69.6		EDK 65
70.0	80.0	2.15	4.0	74.6		EDK 70
75.0	85.0	2.15	4.0	79.6	PW/HH 75-85-2.15/79.6	EDK 75
78.0	88.0	2.15	4.0	82.6		EDK 78
80.0	90.0	2.15	4.0	84.6	PW/HH 80-90-2.15/84.6	EDK 80
90.0	100.0	2.15	4.0	94.6		EDK 90
100.0	110.0	2.15	4.0	104.6		EDK 100
110.0	120.0	2.15	4.0	114.6		EDK 110
115.0	125.0	2.15	4.0	119.6		EDK 115
120.0	130.0	2.15	4.0	124.6		EDK 120
127.0	137.0	2.15	4.0	131.6		EDK 127
130.0	140.0	2.15	4.0	134.6		EDK 130
140.0	150.0	2.15	4.0	144.6		EDK 140
170.0	185.0	3.15	6.0	177.0		EDK 170