

Guide Ring Tape

Wear Rings

SP-507

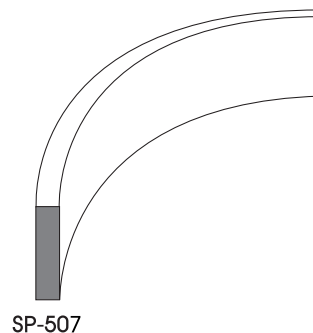

Material	Dynamic Load (N/mm ²)	Temp. (°C)	Speed (m/s)
Polyester Fabric	53	-40 +120	5

- Good sliding properties.
- Excellent for high side-load.
- High wear resistance.
- Long service life.

Installation Recommendation

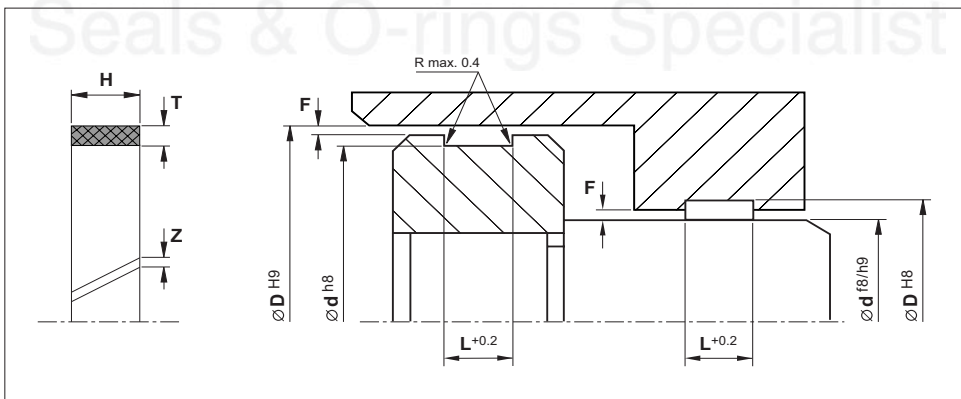

Surface roughness	Ra	Rt	Bore/Rod		Clearance F	
			D/d	F min.	F max.	
Sliding surface	≤ 0.3 µm	≤ 4 µm	8 - 20	0.20	0.30	
Surface of housing	≤ 1.8 µm	≤ 10 µm	20 - 100	0.25	0.40	
Sides of housing	≤ 3.0 µm	≤ 16 µm	101 - 250	0.30	0.60	
			251 - 500	0.40	0.80	
			501 - 1000	0.50	1.10	

Guide Ring Tape

(Metric Size)

Groove Dia.			Wear Ring Width	Wear Ring Thickness	Reference (For order processing)
d	D	L	H	T	
D - 3	d + 3	4.2	4.0	1.5	SP-XX-15042
D - 4	d + 4	4.2	4.0	2.0	SP-XX-20042
D - 5	d + 5	5.6	5.2	2.5	SP-506-25056
D - 4	d + 4	5.7	5.5	2.0	SP-XX-20057
D - 5	d + 5	5.7	5.5	2.5	SP-XX-25057
D - 4	d + 4	6.3	6.1	2.0	SP-XX-20063
D - 5	d + 5	6.3	6.1	2.5	SP-XX-25063
D - 4	d + 4	8.1	7.9	2.0	SP-XX-20081
D - 5	d + 5	8.1	7.9	2.5	SP-XX-25081
D - 6	d + 6	8.1	7.9	3.0	SP-XX-30081
D - 8	d + 8	8.1	7.9	4.0	SP-XX-40081
D - 4	d + 4	9.7	9.5	2.0	SP-XX-20097
D - 5	d + 5	9.7	9.5	2.5	SP-XX-25097
D - 6	d + 6	9.7	9.5	3.0	SP-XX-30097
D - 8	d + 8	9.7	9.5	4.0	SP-XX-40097
D - 5	d + 5	12.7	12.5	2.5	SP-XX-25127
D - 6.2	d + 6.2	12.7	12.5	3.1	SP-XX-31127
D - 5	d + 5	13.0	12.6	2.5	SP-506-25130
D - 3	d + 3	15.0	14.8	1.5	SP-XX-15150
D - 4	d + 4	15.0	14.8	2.0	SP-XX-20150
D - 5	d + 5	15.0	14.8	2.5	SP-XX-25150
D - 6	d + 6	15.0	14.8	3.0	SP-XX-30150
D - 6.2	d + 6.2	19.0	18.5	3.1	SP-XX-31190
D - 6	d + 6	20.0	19.5	3.0	SP-XX-30200
D - 5	d + 5	20.0	19.8	2.5	SP-XX-25200
D - 6	d + 6	25.0	24.5	3.0	SP-XX-30250
D - 5	d + 5	25.0	24.6	2.5	SP-506-25250
D - 5	d + 5	25.0	24.8	2.5	SP-XX-25250
D - 6	d + 6	30.0	29.5	3.0	SP-XX-30300
D - 5	d + 5	30.0	29.8	2.5	SP-XX-25300
D - 6	d + 6	40.0	39.5	3.0	SP-XX-30400
D - 6	d + 6	50.0	49.5	3.0	SP-XX-30500

* For order processing, if you need material PTFE+Bronze for ring width 4.0 mm., thickness 1.5 mm.
The computer code will be SP-55-15042

Recommended Ring Gap

Bore Range mm.	Rod Range mm.	Z Gap mm.
10 - 24.9	8 - 19.9	1.0 - 1.5
25 - 44.9	20 - 39.9	1.5 - 2.0
45 - 79.9	40 - 74.9	2.0 - 4.0
80 - 129.9	75 - 124.9	3.0 - 5.0
130 - 349.9	125 - 299.9	4.0 - 6.0
350 - 1000.0	300 - 1000.0	5.0 - 8.0

The Calculation when cutting from rolls, length (A) is calculated as follows :

$$\text{For Piston } A = \pi \times (D - T) - Z$$

$$\text{For Rod } A = \pi \times (d + T) - Z$$

A = Length to cut

D = Bore diameter

d = Rod diameter

T = Thickness of selected tape

Z = Gap

Guide Ring Tape

(Inch Size)

Groove Dia.			Wear Ring Width	Wear Ring Thickness	Reference (For order processing)
d	D	L	H	T	
D - 0.25	d + 0.25	0.375	0.365	0.125	SP-506-1250375
D - 0.25	d + 0.25	0.500	0.496	0.125	SP-506-1250500
D - 0.25	d + 0.25	0.625	0.620	0.125	SP-506-1250625
D - 0.25	d + 0.25	0.750	0.737	0.125	SP-506-1250750
D - 0.25	d + 0.25	1.000	0.988	0.125	SP-506-1251000

* For order processing, if you need material Polyester Fabric for ring width 0.365 inch., thickness 0.125 mm. The computer code will be **SP-506-1250375**

Recommended Ring Gap

Bore Range inch.	Rod Range inch.	Z Gap inch.
0.393 - 0.980	0.315 - 0.783	0.039 - 0.059
0.981 - 1.768	0.784 - 1.572	0.059 - 0.079
1.769 - 3.146	1.573 - 2.952	0.079 - 0.157
3.147 - 5.115	2.953 - 4.920	0.118 - 0.197
5.116 - 13.776	4.921 - 11.810	0.157 - 0.236
13.777 - 40.00	11.811 - 40.00	0.197 - 0.315

The Calculation when cutting from rolls, length (A) is calculated as follows :

$$\text{For Piston } A = \pi \times (D - T) - Z$$

$$\text{For Rod } A = \pi \times (d + T) - Z$$

A = Length to cut

D = Bore diameter

d = Rod diameter

T = Thickness of selected tape

Z = Gap

Seals & O-rings Specialist