

Piston & Rod Seals

UHS

(Metric Size)

(Size list on page 111-121)

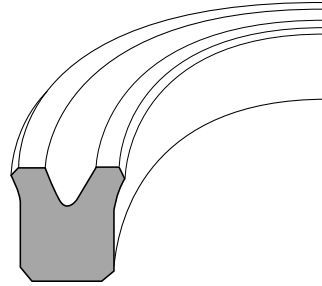

UHS

Type	Material	Pressure (Bar)	Temp. (°C)	Speed (m/s)
UHS	PU	210 (450)	- 25 +80	1

- Simple groove design.
- Good wear resistance.
- Easy installation.

Installation Recommendation

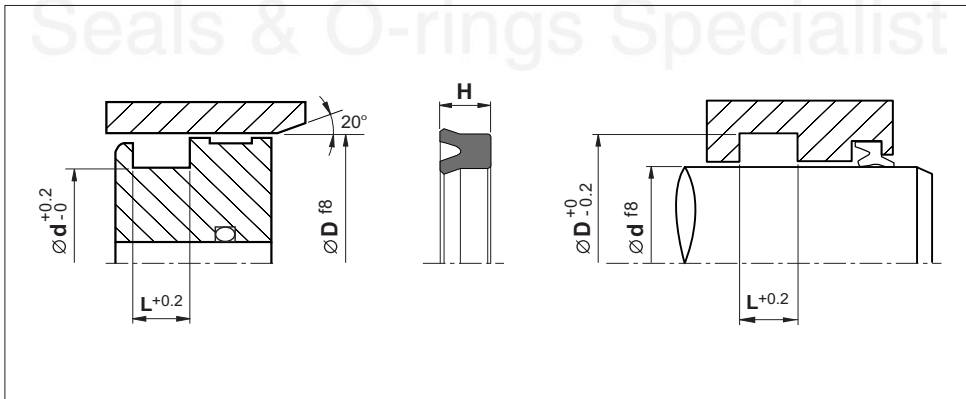

Surface roughness	Ra	Rt
-------------------	----	----

Sliding surface	≤ 0.3 μm	≤ 4 μm
Surface of housing	≤ 1.8 μm	≤ 10 μm
Sides of housing	≤ 3.0 μm	≤ 16 μm

U-Cup

(Metric Size)

Rod/ Groove Dia.	Bore/ Groove Dia.	Seal Height	Groove Width	Reference	Reference	Reference	Reference
d	D	H	L				
3.0	9.0	4.5	5.0	UPN 003-009			
4.0	8.0	4.5	5.0	UPN 004-008			
4.0	10.0	4.0	4.5	UPN 004-010/A			
4.0	10.0	4.5	5.0	UPN 004-010			
4.5	11.0	5.0	5.5	UPN 004.5-011			
4.5	12.5	4.4	5.0		UC 004.5-012.5-04.4 H601	4506701	
4.5	12.5	4.5	5.0	UPN 004.5-012.5			
5.0	12.0	5.0	5.5	UPN 005-012/A			
5.0	12.0	5.5	6.5		UC 005-012-05.5 H601	4508601	
5.0	12.0	6.0	6.3	UPN 005-012			
5.0	12.0	6.0	6.5	UPN 005-012/B			
5.0	17.0	9.0	10.0	UPN 005-017			
6.0	12.0	4.0	4.5	UPN 006-012/A			
6.0	12.0	5.5	6.0	UPN 006-012/B			
6.0	12.0	6.0	6.5	UPN 006-012			
6.0	12.7	5.5	6.5	UPN 006-012.7			
6.0	13.0	8.0	9.0		UC 006-013-08 H601	4460300	
6.0	15.0	8.0	9.0	UPN 006-015			UNS-006.3
6.3	16.3	8.0	9.0				
7.0	14.0	3.5	4.2	UPN 007-014			
7.0	15.0	7.0	8.0	UPN 007-015			
7.1	17.1	8.0	9.0				UNS-007.1
8.0	12.0	2.4	3.5	UPN 008-012			
8.0	14.0	6.0	7.0	UPN 008-014			
8.0	15.0	5.7	6.3	UPN 008-015			
8.0	15.0	8.0	9.0	UPN 008-015/A			
8.0	16.0	5.7	6.3	UPN 008-016			
8.0	18.0	8.0	9.0				UNS-008
8.0	18.0	9.0	10.0	UPN 008-018			
8.0	22.0	8.0	9.0	UPN 008-022			
9.0	15.0	8.0	9.0	UPN 009-015			
9.0	19.0	6.0	7.0	UPN 009-019			
9.0	19.0	8.0	9.0				UNS-009
10.0	16.0	6.0	6.5	UPN 010-016			
10.0	16.0	6.0	6.5	UPN 010-016/A			
10.0	18.0	5.5	6.0	UPN 010-018/A			
10.0	18.0	6.0	7.0	UPN 010-018/B			
10.0	18.0	6.0	6.6		UC 010-018-06 H601	4299900	
10.0	18.0	8.0	9.0	UPN 010-018			
10.0	20.0	8.0	9.0	UPN 010-020	UC 010-020-08 H601	4600000	UNS-010

* For order processing, the computer code will be
 e.g. UC 003-009-04.5 UPN, UC 004.5-012.5-04.4 H601

(Metric Size)

Rod/ Groove Dia.	Bore/ Groove Dia.	Seal Height	Groove Width	Reference	Reference	Reference	Reference
d	D	H	L				
10.0	22.0	6.0	7.0	UPN 010-022			
10.0	22.0	8.0	9.0	UPN 010-022/A			
11.0	17.0	4.4	5.0	UPN 011-017			
11.0	20.5	6.0	7.0	UPN 011-020.5			
11.2	19.2	5.0	5.7				UHS-011.2
11.2	21.2	8.0	9.0				UNS-011.2
12.0	18.0	6.0	7.0	UPN 012-018	UC 012-020-04.4 H601	4182501	
12.0	20.0	4.4	5.0	UPN 012-020			
12.0	20.0	8.0	9.0	UPN 012-022/A			
12.0	22.0	5.0	6.0				
12.0	22.0	7.0	8.0	UPN 012-022			
12.0	22.0	8.0	9.0	UPN 012-022/B			
12.0	24.0	8.0	9.0	UPN 012-024			
12.0	24.0	9.0	10.0	UPN 012-024/A			
12.0	25.0	8.0	9.0	UPN 012-025	UC 012-025-08 H601	4600100	
12.0	25.0	10.0	11.0	UPN 012-025/A			
12.5	22.5	8.0	9.0				UNS-012.5
14.0	20.0	4.8	5.3	UPN 014-020			
14.0	22.0	4.4	5.0		UC 014-022-04.4 H601	4182601	
14.0	22.0	5.0	5.7		UC 014-022-05 H601	4604000	UHS-014
14.0	22.0	6.0	7.0	UPN 014-022			
14.0	22.0	8.0	9.0	UPN 014-022/A			
14.0	22.0	11.0	12.0	UPN 014-022/B			
14.0	24.0	8.0	9.0	UPN 014-024	UC 014-024-08 H601	4600200	UNS-014
15.0	25.0	8.0	9.0	UPN 015-025	UC 015-025-08 H601	4600300	UNS-015
15.0	27.0	6.0	7.0	UPN 015-027			
15.0	28.0	10.0	11.0	UPN 015-028			
16.0	22.0	4.0	4.5	UPN 016-022/A			
16.0	22.0	5.0	5.5	UPN 016-022			
16.0	24.0	4.4	5.0		UC 016-024-04.4 H601	4182701	
16.0	24.0	5.0	6.0	UPN 016-024/A			
16.0	24.0	5.0	5.7		UC 016-024-05 H601	4604100	UHS-016
16.0	24.0	9.0	10.0	UPN 016-024			
16.0	26.0	5.0	6.0	UPN 016-026			
16.0	26.0	8.0	9.0	UPN 016-026/A	UC 016-026-08 H601	4600400	UNS-016
16.0	28.0	6.0	7.0	UPN 016-028			
16.0	32.0	8.0	9.0	UPN 016-032			
17.0	25.0	10.0	11.0	UPN 017-025			
18.0	25.0	5.0	5.5	UPN 018-025			
18.0	26.0	4.4	5.0		UC 018-026-04.4 H601	4182901	

* For order processing, the computer code will be
e.g. UC 003-009-04.5 UPN, UC 004.5-012.5-04.4 H601

U-Cup

(Metric Size)

Rod/ Groove Dia.	Bore/ Groove Dia.	Seal Height	Groove Width	Reference	Reference	Reference	Reference			
d	D	H	L							
18.0	26.0	5.0	5.7	UPN 018-026/A UPN 018-026/B UPN 018-026	UC 018-026-05 H601	4604200	UHS-018			
18.0	26.0	6.5	7.5							
18.0	26.0	8.0	9.0							
18.0	26.0	8.5	9.5							
18.0	28.0	7.3	8.0		UC 018-028-07.3 H601	4547900				
18.0	28.0	8.0	9.0	UPN 018-028	UC 018-028-08 H601	4600500	UNS-018			
18.0	30.0	8.0	9.0	UPN 018-030						
19.0	25.0	6.0	7.0	UPN 019-025						
20.0	28.0	4.0	5.0	UPN 020-028						
20.0	28.0	4.4	5.0					UC 020-028-04.4 H601	4183001	
20.0	28.0	5.0	5.7	UPN 020-28/A UPN 020-029 UPN 020-030 UPN 020-030/A	UC 020-028-05 H601	4604300	UHS-020			
20.0	28.0	8.0	9.0							
20.0	29.0	5.0	5.5							
20.0	30.0	8.0	9.0							
20.0	30.0	10.0	11.0							
20.0	30.0	10.0	11.0		UC 020-030-08 H601	4600600	UNS-020			
20.0	30.0	10.0	11.0	UPN 020-032						
20.0	35.0	12.0	13.0	UPN 020-035						
20.0	39.0	10.0	11.0	UPN 020-039						
20.0	40.0	10.0	11.0	UPN 020-040						
20.0	40.0	12.0	13.0	UPN 020-040/A						
22.0	28.0	8.0	9.0	UPN 022-028	UC 022-030-04.4 H601	4183101				
22.0	30.0	4.4	5.0							
22.0	30.0	6.0	7.0	UPN 022-030						
22.0	30.0	10.0	11.0	UPN 022-030/A						
22.0	32.0	8.0	9.0	UPN 022-032						
22.0	32.0	10.0	11.0	UPN 022-032/A	UC 022-035-10 H601	4600700	UHS-022.4			
22.0	35.0	10.0	11.0	UPN 022-035						
22.4	30.0	5.0	5.7					UC 022.4-030-05 H601	4604400	UNS-022.4
22.4	32.4	8.0	9.0					UC 022.4-032.4-08 H601	4600800	UHS-023.5
23.5	31.5	5.0	5.7							
24.0	32.0	7.0	8.0	UPN 024-032	UC 025-033-04.4 H601	4183301	UHS-025			
24.0	40.0	8.0	9.0	UPN 024-040						
25.0	33.0	4.4	5.0					UC 025-033-05 H601	4604500	
25.0	33.0	5.0	5.7							
25.0	35.0	5.0	5.5	UPN 025-035						
25.0	35.0	8.0	9.0	UPN 025-035/B	UC 025-035-08 H601	4600900	UNS-025			
25.0	35.0	10.0	11.0	UPN 025-035/A	UC 025-035-10 H601	4362600				
25.0	38.0	8.0	9.0		UC 025-038-08 H601	4601000				
25.0	38.0	10.0	11.0	UPN 025-038						
25.0	40.0	10.0	11.0	UPN 025-040	UC 025-040-10 H601	4601100				

* For order processing, the computer code will be
e.g. UC 003-009-04.5 UPN, UC 004.5-012.5-04.4 H601

(Metric Size)

Rod/ Groove Dia.	Bore/ Groove Dia.	Seal Height	Groove Width	Reference	Reference	Reference	Reference
d	D	H	L				
28.0	35.0	5.0	5.5	UPN 028-035			
28.0	35.5	5.0	5.7		UC 028-035.5-05 H601	4604600	UHS-028
28.0	36.0	6.5	7.5	UPN 028-036			
28.0	36.0	6.5	7.1		UC 028-036-06.5 H601	4506201	
28.0	38.0	8.0	9.0	UPN 028-038			
28.0	38.0	5.6	6.3		UC 028-038-05.6 H601	4183401	
28.0	40.0	10.0	11.0	UPN 028-040	UC 028-040-10 H601	4601200	
28.0	43.0	10.0	11.0		UC 028-043-10 H601	4601300	UNS-028
30.0	38.0	6.0	6.5	UPN 030-038			
30.0	40.0	5.0	5.5	UPN 030-040/A			
30.0	40.0	5.6	6.3		UC 030-040-05.6 H601	4183501	
30.0	40.0	6.0	7.0		UC 030-040-06 H601	4604700	UHS-030
30.0	40.0	10.0	11.0	UPN 030-040	UC 030-040-10 H601	4362700	
30.0	42.0	9.0	10.0	UPN 030-042/A			
30.0	42.0	10.0	11.0	UPN 030-042			
30.0	45.0	10.0	11.0	UPN 030-045	UC 030-045-10 H601	4601400	UNS-030
30.0	50.0	10.0	11.0	UPN 030-050/A			
30.0	50.0	12.0	13.0	UPN 030-050			
31.5	41.5	6.0	7.0		UC 031.5-041.5-06 H601	4604800	UHS-031.5
31.5	46.5	10.2	11.0				UNS-031.5
32.0	40.0	5.5	6.0	UPN 032-040			
32.0	40.0	8.0	9.0	UPN 032-040/A			
32.0	42.0	5.6	6.3		UC 032-042-05.6 H601	4183601	
32.0	42.0	6.0	7.0		UC 032-042-06 H601	4604900	
32.0	42.0	10.0	11.0	UPN 032-042	UC 032-042-10 H601	4362800	
32.0	45.0	10.0	11.0	UPN 032-045			
32.0	50.0	12.0	13.0	UPN 032-050			
34.0	45.0	7.0	8.0	UPN 034-045			
34.0	45.0	9.0	10.0	UPN 034-045/A			
34.0	50.0	14.0	15.0	UPN 034-050			
34.0	70.0	10.0	11.0	UPN 034-070			
34.0	74.0	10.0	11.0	UPN 034-074			
35.0	45.0	6.0	7.0		UC 035-045-06 H601	4605000	UHS-035
35.0	45.0	7.0	8.0		UC 035-045-07 H601	4496000	
35.0	45.0	8.0	9.0	UPN 035-045/A			
35.0	45.0	10.0	11.0	UPN 035-045			
35.0	48.0	10.0	11.0	UPN 035-048	UC 035-048-10 H601	4360300	
35.0	50.0	10.0	11.0	UPN 035-050			
35.0	50.0	10.0	11.0		UC 035-050-10 H601	4601500	UNS-035
35.0	55.0	10.0	11.0	UPN 035-055/A			

* For order processing, the computer code will be
 e.g. UC 003-009-04.5 UPN, UC 004.5-012.5-04.4 H601

U-Cup

(Metric Size)

Rod/ Groove Dia.	Bore/ Groove Dia.	Seal Height	Groove Width	Reference	Reference	Reference	Reference
d	D	H	L				
35.0	55.0	12.0	13.0	UPN 035-055			
35.5	45.0	6.0	7.0		UC 035.5-045-06 H601	4605100	UHS-035.5
35.5	50.5	10.2	11.0				UNS-035.5
36.0	46.0	5.6	6.3		UC 036-046-05.6 H601	4183701	
36.0	46.0	7.0	8.0	UPN 036-046			
36.0	70.0	10.0	11.0	UPN 036-070			
38.0	45.0	5.0	5.5	UPN 038-045			
38.0	46.0	6.5	7.5	UPN 038-046			
38.0	48.0	6.0	7.0		UC 038-048-06 H601	4605200	UHS-038
38.0	50.0	9.0	10.0	UPN 038-050			
38.0	55.0	9.7	11.0		UC 038-055-09.7 H601	4366000	
38.0	55.0	10.0	11.0	UPN 038-055			
38.0	58.0	9.7	11.0		UC 038-058-09.7 H601	4560100	
38.0	58.0	10.0	11.0	UPN 038-058			
40.0	48.0	11.0	12.0	UPN 040-048			
40.0	50.0	5.6	6.3		UC 040-050-05.6 H601	4183801	
40.0	50.0	6.0	7.0		UC 040-050-06 H601	4605300	UHS-040
40.0	50.0	5.6	6.3		UC 040-050-05.6 H601	4183801	
40.0	50.0	6.5	7.5	UPN 040-050/A			
40.0	50.0	8.0	9.0	UPN 040-050/B			
40.0	50.0	10.0	11.0	UPN 040-050	UC 040-050-10 H601	4362900	
40.0	55.0	9.9	11.0		UC 040-055-09.9 H601	4388500	
40.0	55.0	10.0	11.0	UPN 040-055	UC 040-055-10 H601	4601600	UNS-040
40.0	56.0	10.0	11.0	UPN 040-056			
40.0	60.0	10.0	11.0	UPN 040-060/A			
40.0	60.0	12.0	13.0		UC 040-060-12 H601	4601700	
40.0	60.0	13.0	14.0	UPN 040-060			
40.0	60.0	18.0	19.0	UPN 040-060/B			
40.0	65.0	12.0	13.0	UPN 040-065			
40.0	70.0	15.0	16.0	UPN 040-070			
40.0	75.0	10.0	11.0	UPN 040-075			
42.0	50.0	8.0	9.0	UPN 042-050			
42.0	52.0	9.0	10.0	UPN 042-052			
42.0	62.0	12.0	13.0	UPN 042-062			
45.0	55.0	5.6	6.3		UC 045-055-05.6 H601	4183901	
45.0	55.0	6.0	7.0		UC 045-055-06 H601	4605400	UHS-045A
45.0	55.0	6.5	7.5	UPN 045-055/A			
45.0	55.0	10.0	11.0	UPN 045-055	UC 045-055-10 H601	4363000	
45.0	56.0	7.0	8.0		UC 045-056-07 H601	4605500	UHS-045
45.0	60.0	10.0	11.0	UPN 045-060	UC 045-060-10 H601	4601800	UNS-045

* For order processing, the computer code will be
 e.g. UC 003-009-04.5 UPN, UC 004.5-012.5-04.4 H601

(Metric Size)

Rod/ Groove Dia.	Bore/ Groove Dia.	Seal Height	Groove Width	Reference	Reference	Reference	Reference
d	D	H	L				
45.0	63.0	10.0	11.0	UPN 045-063			
45.0	65.0	10.0	11.0	UPN 045-065			
45.0	65.0	12.0	13.0	UPN 045-065/A			
46.0	56.0	6.0	7.0		UC 046-056-06 H601	4543900	
48.0	58.0	10.0	11.0	UPN 048-058			
48.0	63.0	10.0	11.0		UC 048-063-10 H601	4601900	UNS-048
50.0	60.0	5.6	6.3		UC 050-060-05.6 H601	4184001	
50.0	60.0	6.0	7.0		UC 050-060-06 H601	4605600	UHS-050
50.0	60.0	10.0	11.0	UPN 050-060	UC 050-060-10 H601	4363100	
50.0	60.0	11.0	12.0	UPN 050-060/A			
50.0	62.0	9.0	10.0	UPN 050-062			
50.0	63.0	6.0	7.0	UPN 050-063			
50.0	65.0	10.0	11.0	UPN 050-065	UC 050-065-10 H601	4602000	UNS-050
50.0	70.0	10.0	11.0	UPN 050-070			
50.0	70.0	12.0	13.0	UPN 050-070/A	UC 050-070-12 H601	4602100	
50.0	70.0	18.0	19.0	UPN 050-070/B			
52.0	62.0	10.0	11.0		UC 052-062-10 H601	4559000	
52.0	62.0	12.0	13.0	UPN 052-062			
53.0	63.0	6.0	7.0		UC 053-063-06 H601	4605700	UHS-053
53.0	63.0	6.5	7.5	UPN 053-063			
53.0	73.0	12.0	13.0		UC 055-065-06 H601	4605800	UNS-053 UHS-055
55.0	65.0	6.0	7.0				
55.0	65.0	10.0	11.0	UPN 055-065/A			
55.0	65.0	12.0	13.0	UPN 055-065			
55.0	70.0	12.0	13.0	UPN 055-070			
55.0	75.0	12.0	13.0	UPN 055-075	UC 055-075-12 H601	4602200	UNS-055
55.0	80.0	12.0	13.0	UPN 055-080			
56.0	66.0	6.0	7.0		UC 056-066-06 H601	4605900	UHS-056
56.0	71.0	8.4	9.5		UC 056-071-08.4 H601	4184201	
56.0	76.0	12.0	13.0				UNS-056
58.0	68.0	6.0	7.0		UC 060-070-06 H601	4606000	UHS-058
60.0	70.0	6.0	7.0				UHS-060A
60.0	70.0	8.0	9.0	UPN 060-070/A			
60.0	70.0	10.0	11.0	UPN 060-070/B	UC 060-070-10 H601	4363200	
60.0	70.0	12.0	13.0	UPN 060-070			
60.0	71.0	7.0	8.0		UC 060-071-07 H601	4606100	UHS-060
60.0	75.0	10.0	11.0	UPN 060-075/A			
60.0	75.0	12.0	13.0	UPN 060-075			
60.0	76.0	12.0	13.0		UC 060-076-12 H601	4608000	
60.0	80.0	10.0	11.0	UPN 060-080			

* For order processing, the computer code will be
 e.g. UC 003-009-04.5 UPN, UC 004.5-012.5-04.4 H601

U-Cup

(Metric Size)

Rod/ Groove Dia.	Bore/ Groove Dia.	Seal Height	Groove Width	Reference	Reference	Reference	Reference
d	D	H	L				
60.0	80.0	12.0	13.0	UPN 060-080/A	UC 060-080-12 H601	4602300	UNS-060
60.0	80.0	18.0	19.0	UPN 060-080/B			
60.0	85.0	12.5	13.5	UPN 060-085			
60.0	90.0	15.0	16.0	UPN 060-090			
63.0	73.0	6.0	7.0		UC 063-073-06 H601	4606200	UHS-063
63.0	73.0	11.8	13.0	UPN 063-075	UC 063-073-11.8 H601	4363300	
63.0	75.0	10.0	11.0				
63.0	78.0	8.4	9.5	UPN 063-078	UC 063-078-08.4 H601	4184301	
63.0	78.0	10.0	11.0				
63.0	83.0	12.0	13.0				
63.0	83.0	15.0	16.0	UPN 063-083	UC 065-075-06 H601	4606300	UHS-065
65.0	75.0	6.0	7.0				
65.0	75.0	12.0	13.0	UPN 065-075			
65.0	80.0	8.4	9.5				
65.0	80.0	11.0	12.0	UPN 065-080/A			
65.0	80.0	12.0	13.0	UPN 065-080	UC 065-085-12 H601	4602400	UNS-065
65.0	85.0	10.0	11.0	UPN 065-085/A			
65.0	85.0	12.0	13.0	UPN 065-085			
66.0	76.0	8.0	9.0	UPN 066-076			
66.0	80.0	10.0	11.0	UPN 066-080			
66.0	80.0	13.0	14.0	UPN 066-080/A			
67.0	77.0	6.0	7.0				
67.0	77.0	10.0	11.0	UPN 067-077/A			
67.0	77.0	12.0	13.0	UPN 067-077			
67.0	87.0	12.0	13.0				
70.0	80.0	5.0	6.0	UPN 070-080/C	UC 070-080-06 H601	4606400	UHS-070
70.0	80.0	6.0	7.0				
70.0	80.0	8.0	9.0	UPN 070-080/A			
70.0	80.0	10.0	11.0	UPN 070-080/B			
70.0	80.0	12.0	13.0	UPN 070-080			
70.0	85.0	8.4	9.5	UPN 070-085	UC 070-085-08.4 H601	4184501	
70.0	85.0	12.0	13.0				
70.0	90.0	12.0	13.0	UPN 070-090	UC 070-090-12 H601	4602500	UNS-070
70.0	90.0	18.0	19.0	UPN 070-090/A	UC 070-092-12 H601	4602600	
70.0	92.0	12.0	13.0				
70.0	95.0	12.0	13.0	UPN 070-095			
71.0	80.0	6.0	7.0	UPN 075-085	UC 071-080-06 H601	4606500	UHS-071
71.0	91.0	12.0	13.0				
75.0	85.0	6.0	7.0				
75.0	85.0	12.0	13.0				
					UC 075-085-06 H601	4606600	UHS-075
					UC 075-085-12 H601	4363500	

* For order processing, the computer code will be
 e.g. UC 003-009-04.5 UPN, UC 004.5-012.5-04.4 H601

(Metric Size)

Rod/ Groove Dia.	Bore/ Groove Dia.	Seal Height	Groove Width	Reference	Reference	Reference	Reference
d	D	H	L				
75.0	90.0	7.5	8.5	UPN 075-090			
75.0	90.0	10.0	11.0	UPN 075-090/B			
75.0	90.0	12.0	13.0	UPN 075-090/A			
75.0	95.0	12.0	13.0	UPN 075-095	UC 075-095-12 H601	4602700	UNS-075
78.0	93.0	10.5	11.5	UPN 078-093			
80.0	90.0	6.0	7.0		UC 080-090-06 H601	4606700	UHS-080
80.0	90.0	8.0	8.7		UC 080-090-08 H601	4159001	
80.0	90.0	10.0	11.0	UPN 080-090			
80.0	90.0	12.0	13.0	UPN 080-090/A	UC 080-090-12 H601	4363600	
80.0	95.0	8.4	9.5		UC 080-095-08.4 H601	4184601	
80.0	95.0	12.0	13.0	UPN 080-095			
80.0	100.0	10.0	11.0	UPN 080-100			
80.0	100.0	12.0	13.0	UPN 080-100/A	UC 080-100-12 H601	4602800	UNS-080
82.0	92.0	10.0	11.0	UPN 082-092			
84.5	94.0	8.0	8.8	UPN 084.5-094			
85.0	95.0	8.5	9.5	UPN 085-095			
85.0	95.0	12.0	13.0	UPN 085-095/A			
85.0	100.0	8.4	9.5		UC 085-100-08.4 H601	4184701	
85.0	100.0	9.0	10.0		UC 085-100-09 H601	4606800	UHS-085
85.0	100.0	12.0	13.0	UPN 085-100			
85.0	105.0	12.0	13.0	UPN 085-105	UC 085-105-12 H601	4602900	UNS-085
85.0	115.0	15.0	16.0	UPN 085-115			
90.0	100.0	7.0	8.0	UPN 090-100/B			
90.0	100.0	8.0	9.0	UPN 090-100			
90.0	100.0	12.0	13.0	UPN 090-100/A	UC 090-100-12 H601	4363700	
90.0	105.0	8.4	9.5		UC 090-105-08.4 H601	4184801	
90.0	105.0	9.0	10.0		UC 090-105-09 H601	4606900	UHS-090
90.0	105.0	12.0	13.0	UPN 090-105			
90.0	110.0	12.0	13.0	UPN 090-110	UC 090-110-12 H601	4603000	UNS-090
90.0	110.0	18.0	19.0	UPN 090-110/A			
90.0	115.0	22.0	23.0	UPN 090-115			
95.0	110.0	9.0	10.0		UC 095-110-09 H601	4607000	UHS-095
95.0	110.0	12.0	13.0	UPN 095-110			
95.0	110.0	15.0	16.0	UPN 095-110/A			
95.0	112.0	11.0	12.0	UPN 095-112			
95.0	115.0	12.0	13.0	UPN 095-115	UC 095-115-12 H601	4603100	UNS-095
95.0	115.0	18.0	19.0	UPN 095-115/A			
98.0	112.0	9.0	10.0				UHS-098
100.0	115.0	9.0	10.0		UC 100-115-09 H601	4607100	UHS-100
100.0	115.0	12.0	13.0	UPN 100-115			

* For order processing, the computer code will be
e.g. UC 003-009-04.5 UPN, UC 004.5-012.5-04.4 H601

U-Cup

(Metric Size)

Rod/ Groove Dia.	Bore/ Groove Dia.	Seal Height	Groove Width	Reference	Reference	Reference	Reference
d	D	H	L				
100.0	120.0	11.0	12.5		UC 100-120-11 H601	4184901	
100.0	120.0	12.0	13.0	UPN 100-120	UC 100-120-12 H601	4603200	UNS-100
100.0	125.0	12.0	13.0	UPN 100-125			
100.0	125.0	15.0	16.0	UPN 100-125/A			
100.0	130.0	12.0	13.0	UPN 100-130			
105.0	120.0	8.0	9.0	UPN 105-120			
105.0	120.0	15.0	16.0	UPN 105-120/A			
105.0	125.0	11.4	12.5		UC 105-125-11.4 H601	4185001	
105.0	125.0	12.0	13.0	UPN 105-125/A			
105.0	125.0	15.0	16.0	UPN 105-125			
105.0	125.0	15.0	17.0		UC 105-125-15 H601	4603300	
105.0	125.0	16.0	17.0				UNS-105
106.0	120.0	8.5	9.5	UPN 106-120			
106.0	126.0	16.0	17.0				UNS-106
110.0	125.0	12.0	13.0	UPN 110-125			
110.0	125.0	15.0	16.0	UPN 110-125/A			
110.0	130.0	11.0	12.5		UC 110-130-11 H601	4185101	
110.0	130.0	15.0	16.0	UPN 110-130			
110.0	130.0	15.0	17.0		UC 110-130-15 H601	4603400	
110.0	130.0	16.0	17.0				UNS-110
110.0	130.0	18.0	19.0	UPN 110-130/A			
112.0	125.0	9.0	10.0		UC 112-125-09 H601	4607200	UHS-112
112.0	132.0	16.0	17.0				UNS-112
113.0	125.0	9.5	10.5	UPN 113-125			
115.0	126.0	15.0	16.0	UPN 115-126			
115.0	135.0	15.0	16.0	UPN 115-135			
115.0	135.0	15.0	17.0		UC 115-135-15 H601	4608100	
115.0	140.0	15.0	16.0	UPN 115-140/A			
115.0	140.0	22.0	23.0	UPN 115-140			
118.0	138.0	16.0	17.0				UNS-118
120.0	130.0	14.0	15.0	UPN 120-130			
120.0	135.0	15.0	16.0	UPN 120-135			
120.0	140.0	14.5	16.0		UC 120-140-14.5 H601	4319600	
120.0	140.0	15.0	16.0	UPN 120-140			
120.0	140.0	15.0	17.0		UC 120-140-15 H601	4603500	
120.0	140.0	16.0	17.0				UNS-120
125.0	140.0	9.0	10.0		UC 125-140-09 H601	4607300	UHS-125
125.0	140.0	11.0	12.0	UPN 125-140			
125.0	140.0	15.0	16.0	UPN 125-140/A			
125.0	145.0	11.0	12.5		UC 125-145-11 H601	4185201	

* For order processing, the computer code will be
e.g. UC 003-009-04.5 UPN, UC 004.5-012.5-04.4 H601

(Metric Size)

Rod/ Groove Dia.	Bore/ Groove Dia.	Seal Height	Groove Width	Reference	Reference	Reference	Reference			
d	D	H	L							
125.0	145.0	15.0	16.0	UPN 125-145	UC 125-145-15 H601	4603600	UNS-125			
125.0	145.0	15.0	17.0							
125.0	145.0	16.0	17.0							
125.0	145.0	18.0	19.0	UPN 125-145/A						
125.0	155.0	15.0	16.0	UPN 125-155						
130.0	150.0	15.0	16.0	UPN 130-150	UC 130-150-15 H601	4603700	UNS-130			
130.0	150.0	15.0	17.0							
130.0	150.0	16.0	17.0							
135.0	155.0	15.0	16.0	UPN 135-155						
135.0	160.0	15.0	16.0	UPN 135-160						
136.0	150.0	8.5	9.5	UPN 140-155/AI	UC 136-150-08.5 H601	4607400	UHS-136			
136.0	150.0	9.0	10.0							
136.0	154.0	9.0	10.0			UC 136-154-09 H601	4607900	UHS-140		
140.0	155.0	9.0	10.0			UC 140-155-09 H601	4607500			
140.0	155.0	15.0	16.0							
140.0	160.0	12.0	13.0	UPN 140-160/A	UC 140-160-15 H601	4603800	UNS-140			
140.0	160.0	15.0	16.0	UPN 140-160						
140.0	160.0	15.0	17.0							
140.0	160.0	16.0	17.0							
145.0	160.0	9.0	10.0					UC 145-160-09 H601	4607600	UHS-145
145.0	165.0	15.0	16.0	UPN 145-165	UC 145-165-15 H601	4608200				
145.0	165.0	15.0	17.0							
150.0	165.0	8.9	10.0					UC 150-165-08.9 H601	4607700	
150.0	170.0	15.0	16.0	UPN 150-170						
150.0	170.0	15.0	17.0					UC 150-170-15 H601	4603900	
150.0	170.0	16.0	17.0	UPN 150-170/1	UC 155-180-15 H601	4608300	UNS-150			
150.0	170.0	18.0	19.0							
155.0	180.0	15.0	17.0						UC 160-175-09 H601	4608400
160.0	175.0	9.0	10.0							
160.0	180.0	15.0	16.0					UPN 160-180		
160.0	185.0	15.0	17.0	UPN 170-190	UC 160-185-15 H601	4608500				
165.0	180.0	9.0	10.0			UC 165-180-09 H601		4608600		
165.0	183.0	10.0	11.0			UC 165-183-10 H601		4607800		
165.0	190.0	15.0	17.0			UC 165-190-15 H601		4608700		
170.0	190.0	15.0	16.0							
170.0	195.0	15.0	17.0	UPN 170-200	UC 170-195-15 H601	4608800				
170.0	200.0	18.0	19.0							
175.0	200.0	15.0	16.0		UPN 175-200					
175.0	200.0	15.0	17.0			UC 175-200-15 H601		4608900		
180.0	200.0	12.0	13.0			UC 180-200-12 H601		4609000		

* For order processing, the computer code will be
e.g. UC 003-009-04.5 UPN, UC 004.5-012.5-04.4 H601

U-Cup

(Metric Size)

Rod/ Groove Dia.	Bore/ Groove Dia.	Seal Height	Groove Width	Reference	Reference	Reference	Reference
d	D	H	L				
180.0	200.0	15.0	16.0	UPN 180-200			
180.0	205.0	15.0	17.0		UC 180-205-15 H601	4609100	
180.0	220.0	20.0	21.0	UPN 180-220			
190.0	210.0	12.0	13.0		UC 190-210-12 H601	4609200	
190.0	215.0	15.0	17.0		UC 190-215-15 H601	4609300	
200.0	220.0	12.0	13.0		UC 200-220-12 H601	4609400	
200.0	225.0	15.0	17.0		UC 200-225-15 H601	4609500	
200.0	225.0	18.2	19.0	UPN 200-225			
210.0	235.0	18.0	20.0		UC 210-235-18 H601	4609600	
220.0	240.0	12.0	13.0		UC 220-240-12 H601	4609700	
220.0	250.0	17.0	19.2		UC 220-250-17 H601	4426600	
220.0	250.0	18.0	19.0	UPN 220-250			
225.0	245.0	15.0	16.0	UPN 225-245			
230.0	250.0	12.0	13.0		UC 230-250-12 H601	4609800	
240.0	265.0	18.0	20.0		UC 240-265-18 H601	4609900	
245.0	270.0	15.0	16.0	UPN 245-270			
250.0	275.0	18.0	20.0		UC 250-275-18 H601	4610000	
260.0	290.0	18.0	20.0		UC 260-290-18 H601	4620100	
265.0	290.0	17.0	18.0	UPN 265-290			
265.0	295.0	18.0	20.0		UC 265-295-18 H601	4620200	
270.0	290.0	17.0	18.0	UPN 270-290			
270.0	300.0	15.0	16.0	UPN 270-300			
270.0	300.0	18.0	20.0		UC 270-300-18 H601	4620300	
280.0	300.0	15.0	16.0	UPN 280-300			
280.0	310.0	18.0	20.0		UC 280-310-18 H601	4620400	
290.0	320.0	18.0	20.0		UC 290-320-18 H601	4620500	
300.0	330.0	18.0	20.0		UC 300-330-18 H601	4620600	
305.0	320.0	17.0	18.0	UPN 305-320			
360.0	390.0	22.0	23.0	UPN 360-390			
375.0	405.0	22.0	24.0		UC 375-405-22 H601	4620700	
400.0	425.0	25.0	27.0		UC 400-425-25 H601	4620800	
450.0	485.0	25.0	27.0		UC 450-485-25 H601	4620900	

* For order processing, the computer code will be
e.g. UC 003-009-04.5 UPN, UC 004.5-012.5-04.4 H601