

Rod Seals

HLTS

(Metric Size)

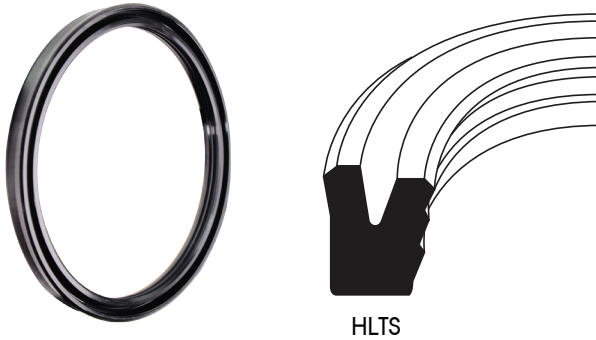

Material	Pressure (Bar)	Temp. (°c)	Speed (m/s)
PU	350	-50/+105	0.5

- Multi-lip u-cup with the pressure-compensation characteristics
- Multi lips serve two purpose: dry rod performance and minimize friction.
- Suitable for low speed applications

Installation Recommendation

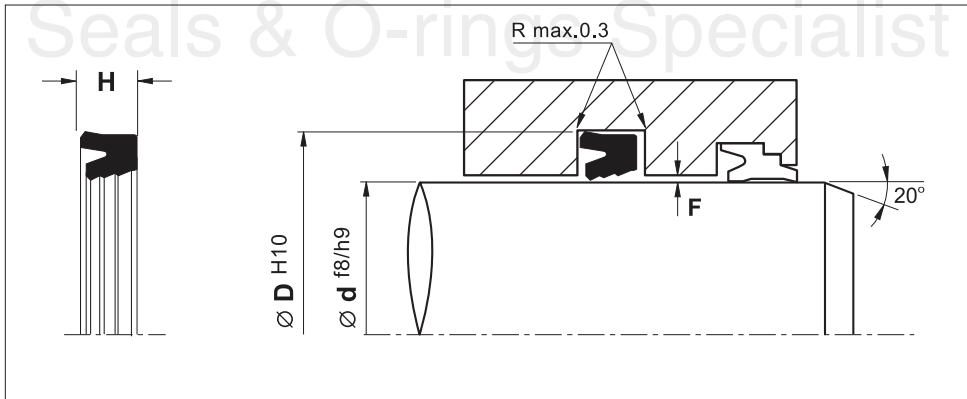

Surface roughness	Ra	Rt	Chamfers	
Sliding surface	≤ 0.3 µm	≤ 4 µm	D	C
Surface of housing	≤ 1.8 µm	≤ 10 µm	< 60	4.0
Sides of housing	≤ 3.0 µm	≤ 16 µm	60-120	5.0
			120-180	6.5
			180-250	7.5
			250-500	10.0

- ต้องการข้อมูลหรือรายละเอียดเพิ่มเติมติดต่อที่ โทร. 02-8810555 •

ROD U-Cup



(Inch Size)

Nominal part size				Reference	Reference
ID	OD	H	CS		
5/8	7/8	0.17	1/8	HLTS-051	HMU12-0.62-17U
1/2	3/4	7/32	1/8		HMU12-0.50-21U
5/8	7/8	7/32	1/8	HLTS-061	HMU12-0.62-21U
1	1-1/4	1/4	1/8	HLTS-101	HMU12-1.00-25U
1	1-5/16	7/32	5/32		HMU15-1.00-21U
1-3/8	1-11/16	0.24	5/32	HLTS-131	HMU15-1.37-24U
1-3/8	1-3/4	5/16	3/16	HLTS-171	HMU18-1.37-31U
1-3/4	2-1/8	0.27	3/16		HMU18-1.75-27U
1-3/4	2-1/8	3/8	3/16	HLTS-201	HMU18-1.75-38U
2	2-3/8	0.27	3/16		HMU18-2.00-27U
2	2-3/8	3/8	3/16	HLTS-251	HMU18-2.00-38U
2-1/2	2-7/8	3/8	3/16		HMU18-2.50-38U
3	3-3/8	3/8	3/16	HLTS-301	HMU18-3.00-38U
3-1/2	3-7/8	3/8	3/16		HMU18-3.50-38U
2-1/2	2.93	0.30	7/32	HLTS-351	HMU21-2.50-30U
3	3-7/16	0.3	7/32	HLTS-401	HMU21-3.00-30U
3-1/2	4	0.33	1/4	HLTS-451	HMU25-3.50-33U
4	4-1/2	0.33	1/4	HLTS-501	HMU25-4.00-33U
4-1/2	5	0.33	1/4	HLTS-551	HMU25-4.50-33U
5	5-9/16	0.355	9/32	HLTS-551	HMU28-5.00-35U
5-1/2	6.12	0.38	5/16		HMU31-5.50-38U

Seals & O-rings Specialist