

Piston Seals (Single Acting)

KDA

(Metric Size)

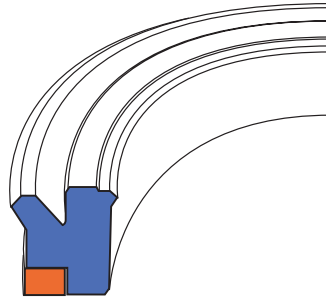

KDA

Material	Pressure (Bar)	Temp. (°C)	Speed (m/s)
PU-Acetal	500	-40 +100	(0.5)

- Very high resistance against extrusion.
- Extended service life.
- Simply groove design.

Installation Recommendation

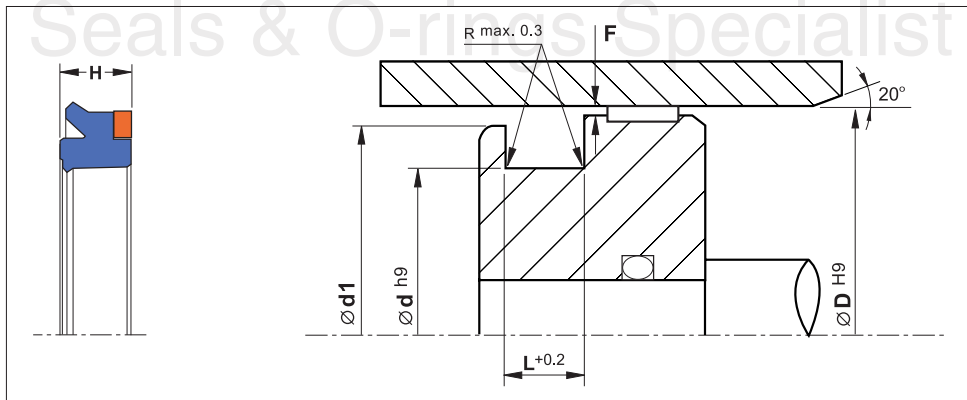

	Surface roughness	Ra	Rt	Pressure		Clearance F Max	
				Bar	D <60 mm	D >60 mm	D <60 mm
Sliding surface	≤ 0.3 μm	≤ 4 μm		50	0.40	0.50	
Surface of housing	≤ 1.8 μm	≤ 10 μm		100	0.30	0.40	
Sides of housing	≤ 3.0 μm	≤ 16 μm		200	0.20	0.30	
				300	0.15	0.20	
				400	0.10	0.15	

- ต้องการข้อมูลเพิ่มเติมหรือรายละเอียดเพิ่มเติมติดต่อที่ โทร. 02-8810555 •

Piston U-Cup

(Metric Size)

Bore Dia.	Groove Dia.	Groove Width	Fitting Dia.	Reference	
D	d	L	d1		
35	25.0	8.5	30	KDA 35-25-8	
40	25.0	9.5	35	KDA 40-25-9	
45	30.0	9.5	40	KDA 45-30-9	
45	35.0	6.5	40	KDA 45-35-6	
45	35.0	9.5	40	KDA 45-35-9	
48	40.0	6.3	44	KDA 48-40-5.8	
50	35.0	9.5	45	KDA 50-35-9	
50	40.0	9.5	45	KDA 50-40-9	
55	40.0	9.5	50	KDA 55-40-9	
55	45.0	6.5	50	KDA 55-45-6	
60	40.0	14.5	54	KDA 60-40-14	
60	45.0	9.5	55	KDA 60-45-9	
63	48.0	9.5	58	KDA 63-48-9	
65	50.0	9.5	60	KDA 65-50-9	
70	50.0	12.5	64	KDA 70-50-12	
70	55.0	9.5	64	KDA 70-55-9	
75	55.0	12.5	69	KDA 75-55-12	
80	60.0	12.5	74	KDA 80-60-12	
80	60.0	14.5	74	KDA 80-60-14	
80	65.0	9.5	75	KDA 80-65-9	
85	69.9	6.3	75	KDA 85-69.9-5.8	
85	70.0	9.5	80	KDA 85-70-9	
90	70.0	12.5	84	KDA 90-70-12	
90	75.0	9.5	85	KDA 90-75-9	
100	80.0	12.5	94	KDA 100-80-12	
100	84.5	6.3	90	KDA 100-84.5-5.8	
100	85.0	9.5	95	KDA 100-85-9	
100	85.0	14.5	95	KDA 100-85-14	
105	85.0	12.5	99	KDA 105-85-12	
110	90.0	12.5	104	KDA 110-90-12	
110	95.0	9.5	105	KDA 110-95-9	
115	95.0	12.5	109	KDA 115-95-12	
120	104.5	6.3	110	KDA 120-104.5-5.8	
120	105.0	9.5	115	KDA 120-105-9	
125	100.0	15.5	117	KDA 125-100-15	

Piston U-Cup



(Metric Size)

Bore Dia.	Groove Dia.	Groove Width	Fitting Dia.	Reference	
D	d	L	d1		
125	105.0	12.5	119	KDA 125-105-12	
130	110.0	12.5	124	KDA 130-110-12	
130	114.5	6.3	120	KDA 130-114.5-5.8	
140	115.0	15.5	132	KDA 140-115-15	
140	120.0	12.5	134	KDA 140-120-12	
145	125.0	15.5	139	KDA 145-125-15	
150	120.0	19.0	140	KDA 150-120-18.5	
150	130.0	12.5	144	KDA 150-130-12	
160	130.0	19.0	150	KDA 160-130-18.5	
160	140.0	12.5	154	KDA 160-140-12	
170	150.0	12.5	164	KDA 170-150-12	
180	150.0	19.0	170	KDA 180-150-18.5	
180	160.0	12.5	174	KDA 180-160-12	
190	170.0	12.5	184	KDA 190-170-12	
198	178.0	13.0	192	KDA 198-178-12.5	
200	170.0	19.0	190	KDA 200-170-18.5	
200	175.0	15.5	192	KDA 200-175-15	
220	200.0	15.5	214	KDA 220-200-15	
250	220.0	19.0	240	KDA 250-220-18.5	
250	225.0	15.5	242	KDA 250-225-15	

Seals & O-rings Specialist